

34

20
20

30

株式会社ジョイフル

45

(E03196)

	1
	1
	1
	3
	3
	3
	5
	5
	6
	8
	8
	8
	8
	9
	9
	9
	11
	11
(1	11
(2	11
(3	11
(4	11
(5	12
(6	12
	13
	13
	14
	15
(1	15
(2	39
	40
(1	40
(2	59
	60
	61

【表紙】

20 25
34 20 20 30

Joyfull Co., Ltd

)

)

第一部【企業情報】

第1【企業の概況】

1【主要な経営指標等の推移】

(1)

	32	33	34	32	33
	18	19	20	18	19
	18 30	19 30	20 30	18 12 31	19 12 31
	30,345,929	31,468,268	30,465,822	62,911,459	64,398,961
	1,249,286	1,243,326	249,177	3,197,685	2,955,206
	281,777	435,023	216,537	106,360	1,077,196
	12,335,502	12,274,961	11,830,062	12,281,426	12,472,494
	33,752,575	33,991,766	34,816,232	34,400,647	34,952,505
	419.42	417.37	402.25	417.58	424.09
	9.58	14.79	7.36	3.62	36.63
	36.5	36.1	34.0	35.7	35.7
	2,049,839	1,095,992	552,043	4,402,403	2,929,165
	8,804	135,202	420,337	73,192	2,298,582
	2,822,613	856,548	438,744	3,163,772	709,978
	1,271,761	3,305,411	3,696,526	3,201,170	3,121,356
	1,367	1,372	1,404	1,329	1,332
[]	[7,120]	[7,265]	[7,316]	[7,283]	[7,364]

(2)

	32	33	34	32	33
	18	19	20	18	19
	18 30	19 30	20 30	18 12 31	19 12 31
	30,332,272	31,453,440	30,449,142	62,877,173	64,377,713
	1,266,419	1,243,336	343,351	3,212,923	2,955,444
	264,192	435,068	121,117	107,610	1,076,694
	1,596,595	1,596,595	1,596,595	1,596,595	1,596,595
	31,931,900	31,931,900	31,931,900	31,931,900	31,931,900
	12,352,349	12,275,518	11,912,225	12,281,938	12,472,504
	33,758,196	33,982,809	34,849,173	34,392,303	34,945,473
	419.99	417.39	405.04	417.60	424.09
	8.98	14.79	4.12	3.66	36.61
	15	15	15	30	30
	36.6	36.1	34.2	35.7	35.7
	1,354	1,355	1,334	1,320	1,316
[]	[7,114]	[7,265]	[7,306]	[7,273]	[7,364]

2 【事業の内容】

20

11

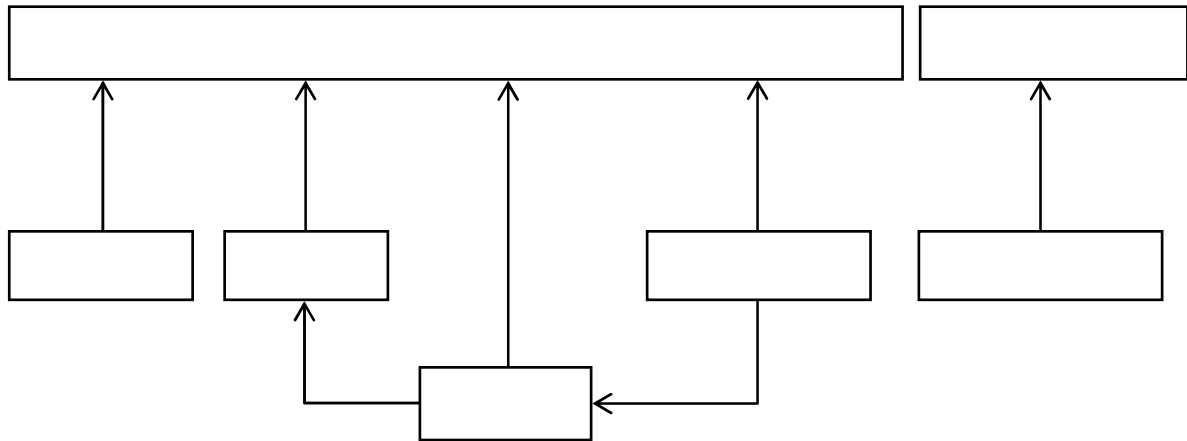

3 【関係会社の状況】

		288,036		100	

4 【従業員の状況】

(1)

20 30

	1,404 (7,316)
--	---------------

1,048

131

90

(2)

20 30

	1,334 (7,306)
--	---------------

1,048

131

(3)

15,767 11 25
 20 30

2 【生産、受注及び販売の状況】

(1)

	938,443	112.0
	327,103	136.8
	141,382	102.1
	1,406,930	115.7

(2)

(3)

	6,486,108	21.9	96.5
	6,989,764	23.6	100.7
	6,791,660	22.9	90.4
	1,019,039	3.4	103.5
	6,784,164	22.9	99.4
	1,561,970	5.3	95.6
	29,632,708	100.0	96.8

(

1

55,291

76,499

660,918

645,884

107,471

105,703

9,432

14,827

3 【対処すべき課題】

4 【経営上の重要な契約等】

5 【研究開発活動】

第3【設備の状況】

1【主要な設備の状況】

2【設備の新設、除却等の計画】

1

									()
				73,327					

2

						()
				56,839	20 1	114
1				72,235	20 6	114
				70,322	20 5	133

1

	664		231,180	20 6

						()
					20 6	134

)

3

									()
				103,000	9,000		20	20	170

						()
	6			11,648	20 10	932

第4【提出会社の状況】

1【株式等の状況】

	120,000,000
	120,000,000

	20 30	20 25		
	31,931,900	31,931,900		
	31,931,900	31,931,900		

20 1 1 20 6 30		31,931,900		1,596,595		2,390,432

	17	9,673	30.29
		1,589	4.97
		1,587	4.97
	10	1,460	4.57
		906	2.83
	50 BANK STREET CANARY WH ARF LONDON E14 NT. UK		
		856	2.68
	11		
		679	2.12
	49 AVENE JF KENNEDY L 855 LUXEMBURG		
506155		659	2.06
		560	1.75
		460	1.44
		18,432	57.72

2,521

	2,521,800		
	29,400,000	294,000	
	10,100		
	31,931,900		
		294,000	

26

2,500

25

	45	2,521,800		2,521,800	7.89
		2,521,800		2,521,800	7.89

2 【株価の推移】

	20					
	1,028	990	989	985	980	984
9	920	2 940	9981	9 950	950	729

3 【役員の状況】

第5【経理の状況】

1. 中間連結財務諸表及び中間財務諸表の作成方法について

(1) 24 11

19 19 30
20 20 30

(2) 52 38

19 19 30
20 20 30

2. 監査証明について

193 19 19 30 19 30
193 19 19 30 20 20
30 20 20 30 20

1 【中間連結財務諸表等】

		19 30		20 30		19 12 31		
			3,325,411		5,316,479		5,121,356	
			141,372		134,589		156,909	
					509,983			
			1,052,451		1,056,553		1,382,120	
			743,236		751,529		493,531	
			180,527		201,092		158,682	
			70,371		69,683		70,126	
			176,848		259,963		298,932	
			162		4,497		2,682	
10			6,619		5,129		5,997	
			5,683,762	16.7	8,299,242	23.8	7,678,344	22.0
()		27,720,700		27,232,878		27,374,500		
()		15,288,563	12,432,137	16,432,070	10,800,807	15,917,825	11,456,675	
()		1,554,546		1,704,517		1,642,191		
()		1,248,532	306,013	1,315,109	389,407	1,293,039	349,151	
()		8,012,074		7,748,525		7,897,546		
()		6,838,675	1,173,399	6,921,425	827,099	6,940,980	956,565	
()			8,692,045		8,692,045		8,692,045	
()			5,442		112,221		25,634	
			22,609,038	66.5	20,821,582	59.8	21,480,073	61.5
()			50,885		53,745		60,697	
()			53,127		53,127		53,127	
()			4,168					
			108,181	0.3	106,873	0.3	113,824	0.3
()			76,369		72,739		69,881	
()			727,090		680,973		704,311	
()			130,160		108,080		112,107	
()			1,274,539		1,315,855		1,395,914	
()			3,382,433		3,410,695		3,397,857	
()			190		190		190	
			5,590,782	16.5	5,588,533	16.1	5,680,263	16.2
			28,308,003	83.3	26,516,989	76.2	27,274,161	78.0
			33,991,766	100.0	34,816,232	100.0	34,952,505	100.0

19

19

30

18 12 31	1, 596, 595	2, 390, 432	12, 054, 539	3, 769, 750	12, 271, 816
			441, 160		441, 160
			435, 023		435, 023
				155	155
			6, 137	155	6, 292
19 30	1, 596, 595	2, 390, 432	12, 048, 402	3, 769, 905	12, 265, 524

18 12 31	9, 609	9, 609	12, 281, 426
			441, 160
			435, 023
			155
	173	173	173
	173	173	6, 465
19 30	9, 436	9, 436	12, 274, 961

20

20

30

19 12 31	1,596,595	2,390,432	12,249,417	3,770,122	12,466,322
			441,154		441,154
			216,537		216,537
				237	237
			657,691	237	657,929
20 30	1,596,595	2,390,432	11,591,725	3,770,359	11,808,393

19 12 31	6,172		6,172	12,472,494
				441,154
				216,537
				237
	2,230	13,266	15,497	15,497
	2,230	13,266	15,497	642,431
20 30	8,403	13,266	21,669	11,830,062

18 12 31	1,596,595	2,390,432	12,054,539	3,769,750	12,271,816
			882,317		882,317
			1,077,196		1,077,196
				372	372
			194,878	372	194,505
19 12 31	1,596,595	2,390,432	12,249,417	3,770,122	12,466,322

18 12 31	9,609	9,609	12,281,426
			882,317
			1,077,196
			372
	3,437	3,437	3,437
	3,437	3,437	191,068
19 12 31	6,172	6,172	12,472,494

		(19 19 30)	(20 20 30)	(19 19 12 31)
()		1,038,127	72,035	2,292,819
		865,649	752,579	1,733,901
		298,594	238,624	720,075
		48,774	295,035	96,721
		3,098	818	7,269
		15,223	17,649	15,223
		9,089	22,840	22,507
		85,828	88,377	167,552
		102,373	29,958	107,353
		1,363	29	1,363
		119,103	325,566	210,565
		634,130	258,533	384,292
		53,484	40,760	155,204
		218,304	476,465	67,090
		599,678	475,315	83,057
		85,801	149,699	8,533
			105,000	747,983
			172,532	
		67,189	31,476	44,673
		2,250,970	1,091,842	4,973,239
		4,996	16,787	11,828
		86,217	85,285	167,470
		1,073,756	471,300	1,888,433
		1,095,992	552,043	2,929,165

		(19 19 30)	(20 20 30)	(19 19 12 31)
		20,000	2,250,000	2,020,000
		21,197	2,150,000	41,197
			29,922	
		145,442	281,648	336,523
		2,079	20	2,079
			10,000	10,000
		36,831	35,409	72,875
		62,806	56,691	106,967
		32,938	22,495	58,756
		135,202	420,337	2,298,582
		300,000		300,000
		1,100,000	2,400,000	3,200,000
		1,417,712	1,406,315	2,835,243
		296,225		296,225
		95,000	115,000	190,000
		155	237	372
		439,906	439,703	880,588
		856,548	438,744	709,978
			4,718	417
		104,241	575,169	79,813
()		3,201,170	3,121,356	3,201,170
		3,305,411	3,696,526	3,121,356

	19 19 30	20 20 30	19 19 12 31
	(1	(1	(1
	(2	(2	(2
	(1	(1	(1
	(2	(2	(2
(1		()	

	19 19 30	20 20 30	19 19 12 31
(2	<p>10 31</p> <p>10</p> <p>10 20</p> <p>((19</p> <p>30) (</p> <p>19 30 83</p> <p>)) 19</p>	<p>31 10</p> <p>10</p> <p>10 20</p> <p>19</p> <p>3 31</p> <p>5%</p> <p>5%</p> <p>5</p>	<p>10 31</p> <p>10</p> <p>10 20</p> <p>((19</p> <p>30) (</p> <p>19 30 83</p> <p>)) 19</p>
(3			

	19 19 30	20 20 30	19 19 12 31
		() 20 4 1 11,853	
(4)			
(5)			

19 19 30			20 20 30			19 19 12 31		
	()			()			()	
	239,761	22,470		221,911			602,282	22,470
	754			364			14,723	
	34,960	647		16,290			79,951	647
	275,475	23,118		58			696,957	23,118
				238,624				

19 19 30					
	31,931,900			31,931,900	
	31,931,900			31,931,900	
	2,521,232	152		2,521,384	
	2,521,232	152		2,521,384	
152					
(1)					
19 29		441,160	15	18 12 31	19 30
(2)					
19 14		441,157	15	19 30	19 13

20
20 30

	31, 931, 900			31, 931, 900	
	31, 931, 900			31, 931, 900	
	2 521, 582	244		2 521, 826	
	2 521, 582	244		2 521, 826	

244

(1)

20 26		441, 154	15	19 12 31	20 27

(2)

20 12		441, 151	15	20 30	20 17

19
19 12 31

	31, 931, 900			31, 931, 900	
	31, 931, 900			31, 931, 900	
	2 521, 232	350		2 521, 582	
	2 521, 232	350		2 521, 582	

350

(1

19 29		441, 160	15	18 12 31	19 30
19 14		441, 157	15	19 30	19 13

(2

20 26		441, 154	15	19 12 31	20 27

19 19 30	20 20 30	19 19 12 31
<p style="text-align: right;">19 30 3,325,411 20,000</p> <hr/> <p style="text-align: right;">3,305,411</p>	<p style="text-align: right;">20 30 5,316,479 2,100,000 509,983 29,935</p> <hr/> <p style="text-align: right;">3,696,526</p>	<p style="text-align: right;">19 12 31 5,121,356 2,000,000</p> <hr/> <p style="text-align: right;">3,121,356</p>

19 19 30				20 20 30				19 19 12 31			
		()				()				()	
	232,400	91,850	140,549		232,400	103,470	128,929		232,400	97,660	134,739
	26,733	3,119	23,614		169,112	24,848	144,263		94,281	13,056	81,225
	2,540,434	282,473	2,257,960		2,661,561	779,377	1,882,183		2,598,833	534,801	2,064,031
	190,154	49,206	140,947		357,088	92,395	264,692		190,154	66,689	123,464
	2,989,722	426,650	2,563,071		3,420,162	1,000,092	2,420,069		3,115,669	712,208	2,403,460
10				10				10			
		()				()				()	
	950,153	375,583	574,569		950,153	399,337	550,816		950,153	399,337	550,816
	27,872	3,251	24,620		27,872	3,251	24,620		99,659	13,742	85,917
	2,671,633	293,936	2,377,697		2,671,633	293,936	2,377,697		2,733,437	559,369	2,174,067
	201,313	51,870	149,443		201,313	51,870	149,443		201,313	70,396	130,917
	3,850,973	724,642	3,126,331		3,850,973	724,642	3,126,331		3,984,563	1,042,845	2,941,718

19 19 30	20 20 30	19 19 12 31
<p style="text-align: right;">530,970 2,112,497</p> <hr/> <p style="text-align: right;">2,643,468</p>	<p style="text-align: right;">617,252 1,912,048</p> <hr/> <p style="text-align: right;">2,529,300</p>	<p style="text-align: right;">560,828 1,936,961</p> <hr/> <p style="text-align: right;">2,497,789</p>
<p>10</p>		<p>10</p>
<p style="text-align: right;">619,594 2,506,737</p> <hr/> <p style="text-align: right;">3,126,331</p>		<p style="text-align: right;">646,117 2,295,600</p> <hr/> <p style="text-align: right;">2,941,718</p>
<p style="text-align: right;">211,648 184,674 36,088</p>	<p style="text-align: right;">339,040 305,202 45,991</p>	<p style="text-align: right;">529,906 470,285 82,668</p>
<p style="text-align: right;">211,648 211,648</p>		<p style="text-align: right;">529,906 529,906</p>

	19 30			20 30			19 12 31		
	24,639	40,484	15,844	24,639	38,748	14,108	24,639	35,003	10,363
	24,639	40,484	15,844	24,639	38,748	14,108	24,639	35,003	10,363

	19 30		20 30		19 12 31	
1				29,935		
2				450,000		
				30,047		
			35,885	33,990		34,878
			35,885	543,973		34,878

19 30

		8,200	31	31

20 30

19 12 31

20 19 19 30 20
30 19 12 31

90

19 19 30

20 20 30
90

19 19 12 31

19 19 30

20 20 30
10

19 19 12 31

19 19 30	20 20 30	19 19 12 31
417.37	402.25	424.09
14.79	7.36	36.63

	(19 19 30)	(20 20 30)	(19 19 12 31)
	435,023	216,537	1,077,196
	435,023	216,537	1,077,196
	29,410,561	29,410,125	29,410,476

18 12 31	1, 596, 595	2, 390, 432	2, 390, 432	403, 948	10, 000	11, 641, 102	12, 055, 051	3, 769, 750	12, 272, 328
						441, 160	441, 160		441, 160
						435, 068	435, 068		435, 068
								155	155
						6, 091	6, 091	155	6, 246
19 30	1, 596, 595	2, 390, 432	2, 390, 432	403, 948	10, 000	11, 635, 011	12, 048, 960	3, 769, 905	12, 266, 081

18 12 31	9, 609	9, 609	12, 281, 938
			441, 160
			435, 068
			155
	173	173	173
	173	173	6, 419
19 30	9, 436	9, 436	12, 275, 518

19 12 31	1, 596, 595	2, 390, 432	2, 390, 432	403, 948	10, 000	11, 835, 478	12, 249, 427	3, 770, 122	12, 466, 332
						441, 154	441, 154		441, 154
						121, 117	121, 117		121, 117
								237	237
						562, 272	562, 272	237	562, 509
20 30	1, 596, 595	2, 390, 432	2, 390, 432	403, 948	10, 000	11, 273, 206	11, 687, 155	3, 770, 359	11, 903, 822

19 12 31	6, 172	6, 172	12, 472, 504
			441, 154
			121, 117
			237
	2, 230	2, 230	2, 230
	2, 230	2, 230	560, 278
20 30	8, 403	8, 403	11, 912, 225

18 12 31	1,596,595	2,390,432	2,390,432	403,948	10,000	11,641,102	12,055,051	3,769,750	12,272,328
						882,317	882,317		882,317
						1,076,694	1,076,694		1,076,694
								372	372
						194,376	194,376	372	194,003
19 12 31	1,596,595	2,390,432	2,390,432	403,948	10,000	11,835,478	12,249,427	3,770,122	12,466,332

18 12 31	9,609	9,609	12,281,938
			882,317
			1,076,694
			372
	3,437	3,437	3,437
	3,437	3,437	190,566
19 12 31	6,172	6,172	12,472,504

	19 19 30	20 20 30	19 19 12 31
	(1	(1	(1
	(2	(2	(2
	(3	(3	(3
	(4	(4	(4
		() 20 4 1	
		11,853	
	(5	(5	(5
	(1	(1	(1

	19 30	20 30	19 12 31
	23,375,771	24,666,568	24,151,845

19
19 30

	2, 521, 232	152		2, 521, 384	
	2, 521, 232	152		2, 521, 384	

152

20
20 30

	2, 521, 582	244		2, 521, 826	
	2, 521, 582	244		2, 521, 826	

244

19
19 12 31

	2, 521, 232	350		2, 521, 582	
	2, 521, 232	350		2, 521, 582	

350

19 19 30				20 20 30				19 19 12 31			
		()				()				()	
	232,400	91,850	140,549		232,400	103,470	128,929		232,400	97,660	134,739
	26,733	3,119	23,614		169,112	24,848	144,263		94,281	13,056	81,225
	2,540,434	282,473	2,257,960		2,661,561	779,377	1,882,183		2,598,833	534,801	2,064,031
	190,154	49,206	140,947		357,088	92,395	264,692		190,154	66,689	123,464
	2,989,722	426,650	2,563,071		3,420,162	1,000,092	2,420,069		3,115,669	712,208	2,403,460
10				10				10			
		()				()				()	
	950,153	375,583	574,569		950,153	399,337	550,816		950,153	399,337	550,816
	27,872	3,251	24,620		27,872	3,251	24,620		99,659	13,742	85,917
	2,671,633	293,936	2,377,697		2,671,633	293,936	2,377,697		2,733,437	559,369	2,174,067
	201,313	51,870	149,443		201,313	51,870	149,443		201,313	70,396	130,917
	3,850,973	724,642	3,126,331		3,850,973	724,642	3,126,331		3,984,563	1,042,845	2,941,718

19 19 30	20 20 30	19 19 12 31
530,970 2,112,497 <hr/> 2,643,468	617,252 1,912,048 <hr/> 2,529,300	560,828 1,936,961 <hr/> 2,497,789
10		10
619,594 2,506,737 <hr/> 3,126,331		646,117 2,295,600 <hr/> 2,941,718
211,648 184,674 36,088	339,040 305,202 45,991	529,906 470,285 82,668
211,648 211,648		529,906 529,906

19 12 31 19 30 20 30

19 19 30	20 20 30	19 19 12 31
417.39	405.04	424.09
14.79	4.12	36.61

	(19 19 30)	(20 20 30)	(19 19 12 31)
	435,068	121,117	1,076,694
	435,068	121,117	1,076,694
	29,410,561	29,410,125	29,410,476

20 8 12

(.....	441, 151	
(.....	15 00	
(20	30	20 17

第6【提出会社の参考情報】

(1)	33	19	19 12 31	20	27
(2)	32	18	18 12 31		
20	33	19	19 12 31		
20					

第二部【提出会社の保証会社等の情報】

=====

19 12

19 30 19 193 19 12 31 19

19 19 30 19 30

=====

20 11

20 30 20 193 20 12 31 20

20 20 30 20 30

=====

19 12

19 30 19 193 19 12 31 33 19

19 30 19 30 19

=====

20 11

20 30 20 193 20 12 31 34 20

20 30 20 30 20
